

# ISO Standard solenoid valve(5/2 way, 5/3 way)

## ESV200, 300, 400, 600 Series



### Specification

Model	200 Series	300 Series	400 Series	600 Series
Orifice size(Cv) mm <sup>2</sup>	32(Cv=1.8)	42(Cv=2.32)	69(Cv=3.85)	108(Cv=6.0)
Fluid	Air(to be filtered by 40 μm filter element)			
Acting	Internal pilot or external pilot			
Lubrication [Note1]	Not required			
Operating Pressure	Internal pilot	0.2~1.0MPa(2~10bar)(29~145psi)		
	External pilot	0~1.0MPa(0~10bar)(0~145psi)		
Control pressure(External pilot)	0.2~1.0MPa(2~10bar)(29~145psi)			
Proof pressure	1.5MPa(15bar)(215psi)			
Temperature °C	-20~70			
Port size(manifold) [Note2]	1/4"	3/8"	1/2"	3/4"
Port size(end plate)	3/8"	1/2"	3/4"	1"
Voltage range	AC: ±15% DC: ±10%			
Power consumption	AC220V/AC110V: 4.5VA AC24V: 5.0VA DC24V/DC12V: 3.0W			
Activating time (0.5MPa)Open/close	10\20 Series	33\41ms	42\55ms	50\68ms
	30 C\E\P Series	38\50ms	50\62ms	50\68ms
Insulation	B Class			
Protection	IP65			
Installation size	ISO5599-1 standard			

### Symbol

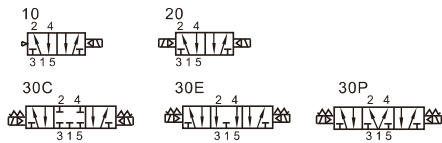

[Note1] Once lubricated air is used, continue with same medium to optimise valve life span. Lubricants like ISO VG32 or equivalent are recommended;  
 [Note2] PT thread and G thread are available.

### Product feature

1. Succinct appearance and compact conformation.
2. The installation size conforms to ISO 5599/1 standard.
3. Because of the special seals, the feature are large flow rate and long lifetime.
4. For 200\300\400 series you can adjust the installation direction of the gasket to change the acting type: internal pilot, external pilot, or air control.
5. You need install the valve together with the sub-base. There are individual and parallel type for manifold sub-base.
6. There are various connection and installation method for manifold. It is easy to use.
7. The manifold of 200\300\400 series have the function of exhaust throttling, so not need to connect another throttle valve.

### Ordering code

#### Ordering code of manifold

ESV 20 1M □ □ □



① Model	② Code	③ Manifold type	④ Thread type	⑤ External pilot port type	⑥ Port position type
ESV: ISO standard solenoid valve	20: 200 Series 30: 300 Series 40: 400 Series 60: 600 Series	1M: Individual sub-base 	Blank: PT G: G	Blank: Individual pilot port	Blank: Side port B: Bottom port
		2M: Manifold sub-base 		Blank: Individual pilot port W: Centralized pilot port	Blank: Left side port R: Right side port B: Bottom port
		3M: End plate kit 		No this code	No this code
	4M: Side port block 	No this code		Blank: Left side port R: Right side port	
	60: 600 Series				

- [Note] 1. For the same model, the port size of the end-plate is bigger than the sub-base (For example ESV202M, the port size of sub-base is 1/4", and the port size of end plate is 3/8").  
 2. Only individual pilot port is available for individual sub-base.  
 3. The manifold sub-base must be used with end plate kit, individual pilot port and centralized pilot port can be mixed.  
 4. 600 series individual sub-base only has side port, 600 series manifold sub-base only has individual pilot port and bottom port.  
 5. Only 600 series have side port block.

# ISO Standard solenoid valve(5/2 way, 5/3 way)

ESV200, 300, 400, 600 Series

## Ordering code

Ordering code of valve

ESV 2 10 A □ □

① ② ③ ④ ⑤ ⑥

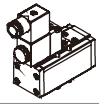
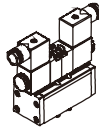
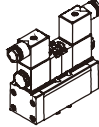
① Model	② Code	③ Valve type	④ Voltage	⑤ Electrical entry	⑥ Pilot type [Note1]
ESV: ISO standard solenoid valve	2: 200 Series 3: 300 Series 4: 400 Series 6: 600 Series	10: Single solenoid 5/2 way 	A: AC220V B: DC24V C: AC110V E: AC24V F: DC12V	Blank: Terminal I: Grommet	Blank: Internal pilot W: External pilot
		20: Double solenoid 5/2 way 			
		30C: Double solenoid 5/3 way closed center 30E: Double solenoid 5/3 way exhaust center 30P: Double solenoid 5/3 way pressure center 			

[Note1] Internal pilot can be changed to external pilot mode(except 600 series), please adjust the installation method of the gasket referring to article 1 o 2 in the installation manual.

Ordering code of accessories

P-ESV200M R2

① ② ③

① Accessories code	② Code	③ Accessories type
P: Unit accessories	ESV200M: 200 Series manifold ESV300M: 300 Series manifold ESV400M: 400 Series manifold ESV600M: 600 Series manifold	R2: Blank plate for manifold

## Inner structure

ESV210 (Terminal)

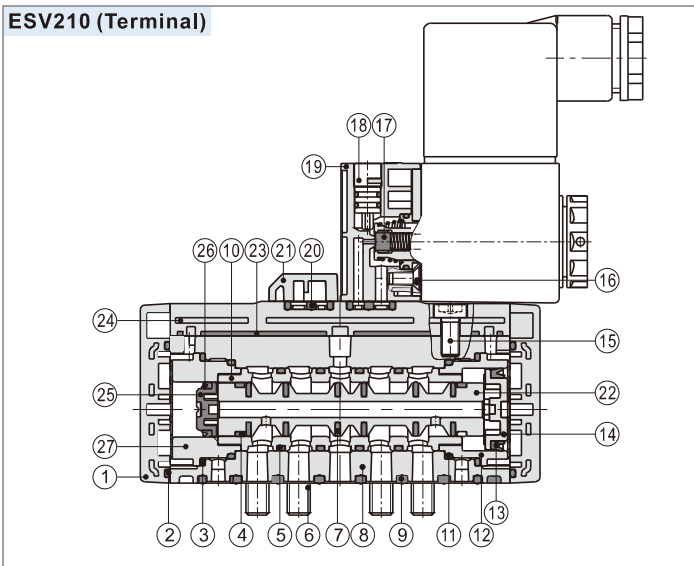

NO.	Item	NO.	Item	NO.	Item
1	Bottom cover	10	Spacer	19	Pilot kit
2	O-ring	11	O-ring	20	Gasket
3	O-ring	12	Big piston sheath	21	Cover plate
4	Wear ring	13	Big piston O-ring	22	Spool
5	O-ring	14	Big piston	23	Upper cover gasket
6	Screw	15	Screw	24	Upper cover
7	O-ring	16	Screw	25	Small piston
8	Body	17	Gasket	26	Small piston O-ring
9	Gasket	18	Manual override	27	Small piston sheath

# ISO Standard solenoid valve(5/2 way, 5/3 way)

## ESV200, 300, 400, 600 Series

### Flow chart

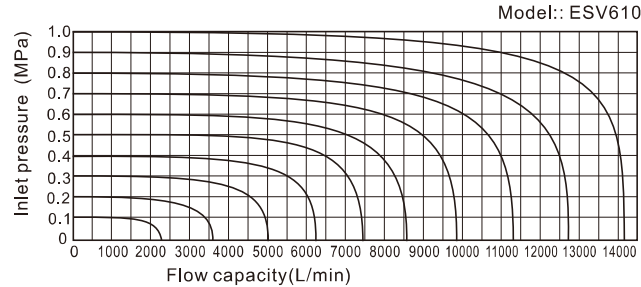
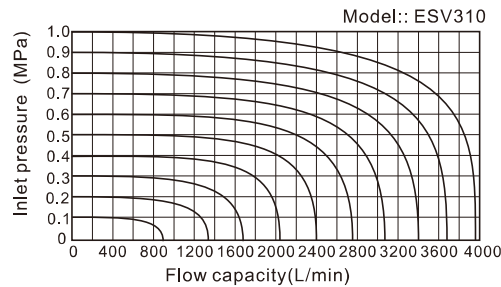
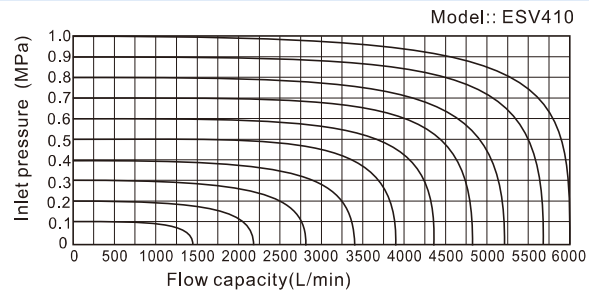
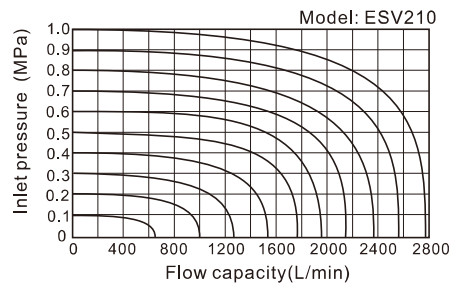

### Installation and operation(For 200, 300, 400 series)

1. The classification and selection for the pilot type of valve
  - 1.1. According to the source of pilot air, we can divide the valve into two types: the internal pilot and external pilot. The standard type is internal pilot.
  - 1.2. You can convert from internal pilot to external pilot by the following methods.

**1** Remove the 4 philips head screws, and then remove the coil, pilot body and cover.

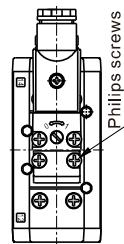

**2** Assemble the gasket according to the picture, and then assemble the cover, pilot body and coil- Internal pilot

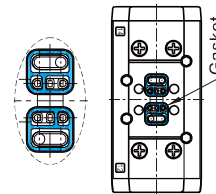

**3** Assemble the pilot O-ring according to the picture, and then, assemble the cover, pilot body and coil-External pilot.

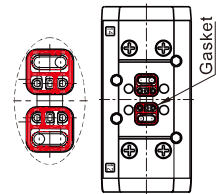

2. The classification and selection for the parallel manifold sub-base
  - 2.1. According to the direction of pilot air supply, we can divide the manifold sub-base into two types: the individual pilot and centralized pilot.
  - 2.2. If you select the individual pilot, the fitting must be connected to the individual pilot ports. If you select the centralized pilot type, the fitting must be connected to the centralized pilot ports.
  - 2.3. If you use parallel manifold, all of the manifold must be used the same pilot type: such as, all of them are the individual pilot type, or all of them are the centralized pilot type.

\* Note: Only when you use the external pilot type, you can select the individual pilot or centralized pilot.

When you use the internal pilot type, the pilot ports on the manifold are ineffective.

3. The position and specification of the manifold sub-base ports:

The diagram of manifold sub-base	Port status of manifold sub-base					
	Port name Ordering code	Left side port	Right side port	Bottom port	Centralized pilot port	Individual pilot port
	ESV202MG	Use	Unused	Unused	Unused	Use
	ESV202MGR	Unused	Use	Unused	Unused	Use
	ESV202MGB	Unused	Unused	Use	Unused	Use
	ESV202MGW	Use	Unused	Unused	Use	Unused
	ESV202MGWR	Unused	Use	Unused	Use	Unused
	ESV202MGWB	Unused	Unused	Use	Use	Unused

Note: Please seal the bottom port by plug, when it is unused.

The above list is an example of 200M series' ordering code, the other series is follow the same pattern, only need to change the series code.

4. Exhaust throttle function
  - 4.1. The manifold has exhaust throttle function, the below picture shows the position of the exhaust throttle orifices on each side.
  - 4.2. Use allen key to adjust the screw.
  - 4.3. Rotate the screw clockwise to reduce the exhaust orifice, rotate the screw counter-clockwise to enlarge the exhaust orifice.

Manifold right side

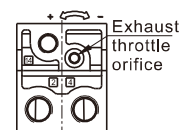

Manifold left side

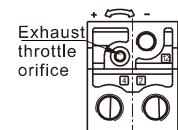

# ISO Standard solenoid valve(5/2 way, 5/3 way)

## ESV200, 300, 400, 600 Series

### Dimensions(ESV200 Series)

ESV210 (Terminal)

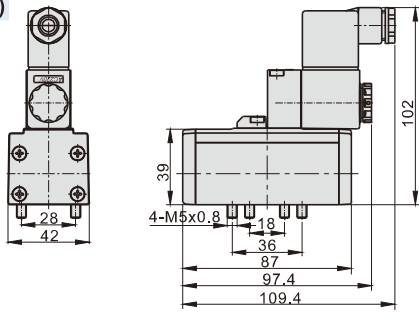

ESV210 (Grommet)

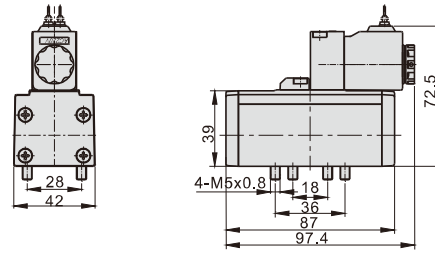

ESV220(Terminal)

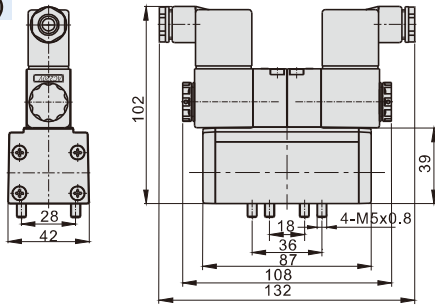

ESV220(Grommet)

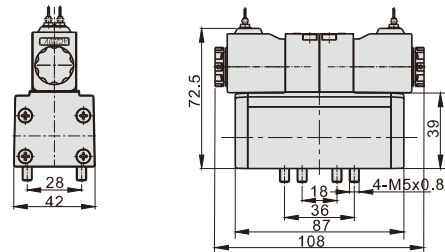

ESV230(Terminal)

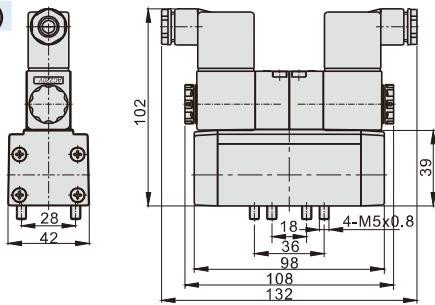

ESV230(Grommet)

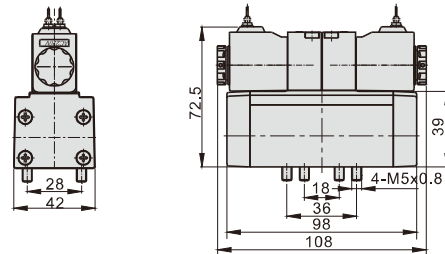

ESV201M

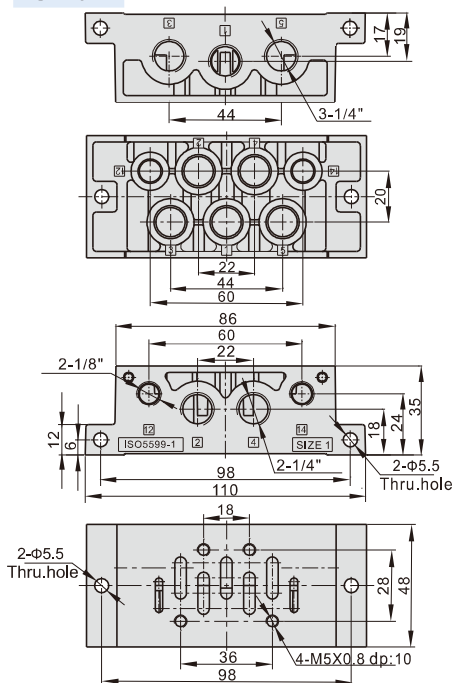

ESV202M

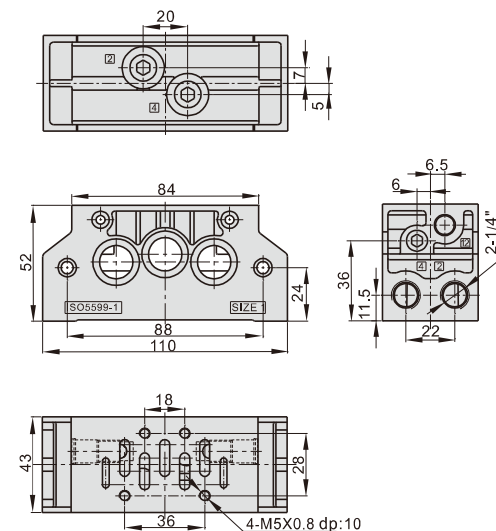

ESV203M

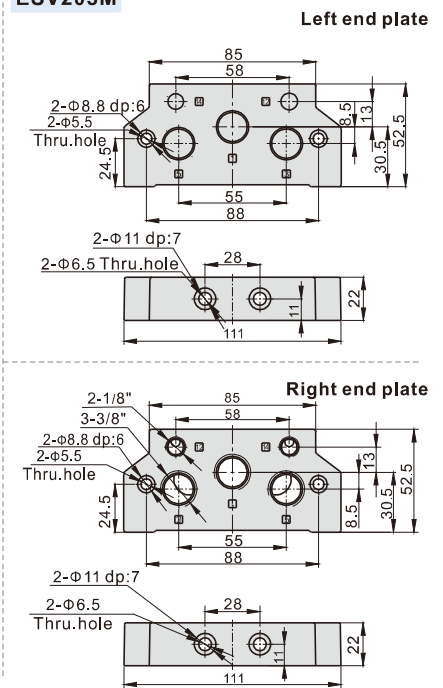

# ISO Standard solenoid valve(5/2 way, 5/3 way)

## ESV200, 300, 400, 600 Series

### ESV210+ESV201M

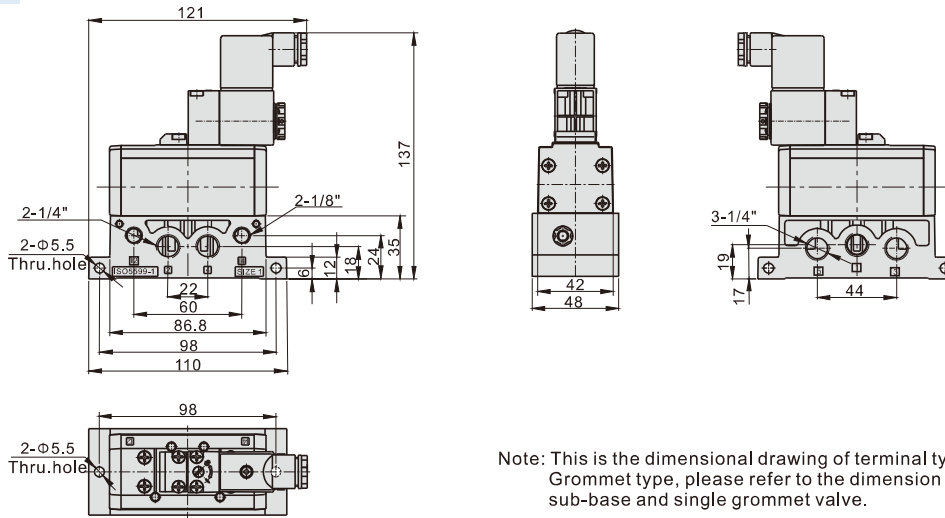

Note: This is the dimensional drawing of terminal type.  
Grommet type, please refer to the dimension of sub-base and single grommet valve.

### ESV220+ESV201M

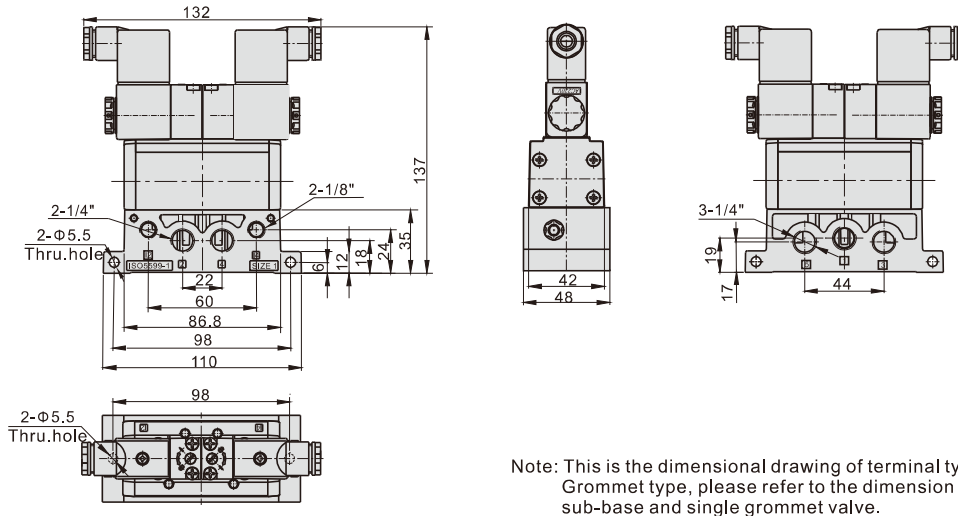

Note: This is the dimensional drawing of terminal type.  
Grommet type, please refer to the dimension of sub-base and single grommet valve.

### ESV230+ESV201M

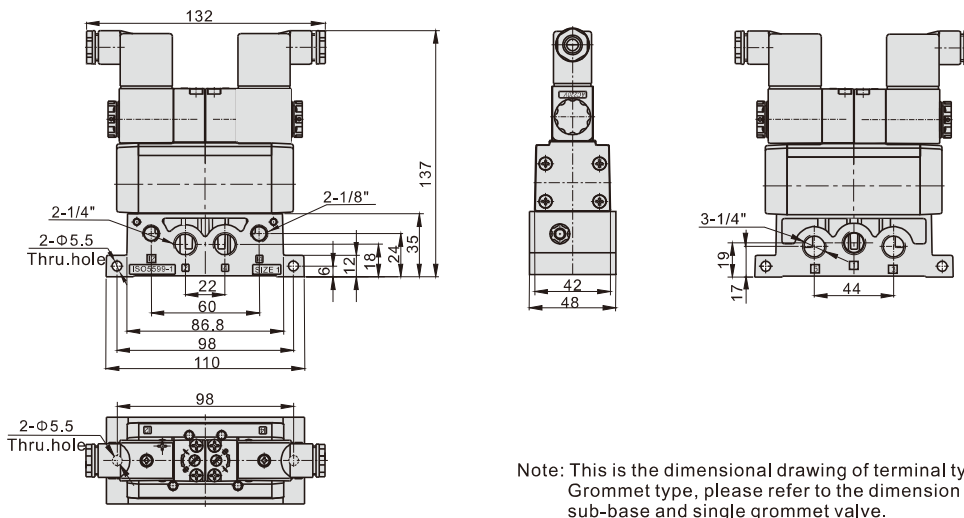

Note: This is the dimensional drawing of terminal type.  
Grommet type, please refer to the dimension of sub-base and single grommet valve.

# ISO Standard solenoid valve(5/2 way, 5/3 way)

## ESV200, 300, 400, 600 Series

### ESV210+ESV202M+ESV203M

Note: "n" means the number of stations.  
The dimension of the grommet type (more than 3 stations), please refer to this drawing and the single grommet valve drawing.

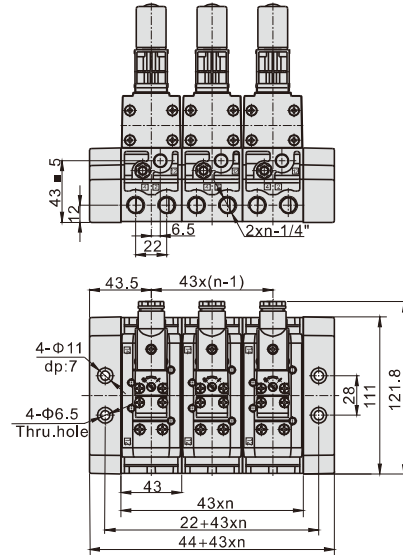
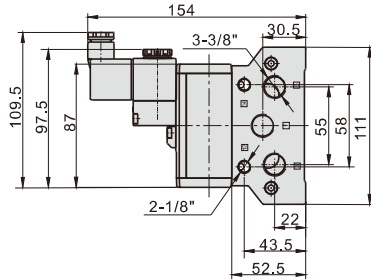

### ESV220+ESV202M+ESV203M

Note: "n" means the number of stations.  
The dimension of the grommet type (more than 3 stations), please refer to this drawing and the single grommet valve drawing.

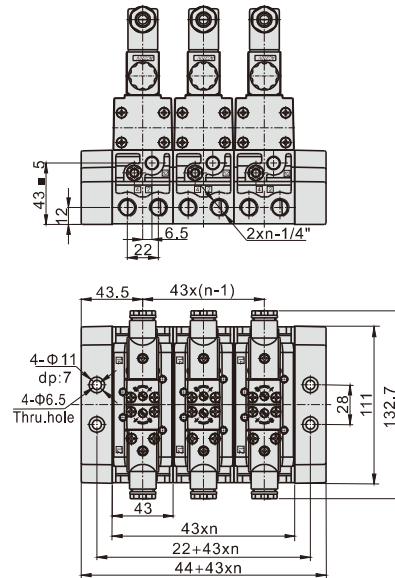
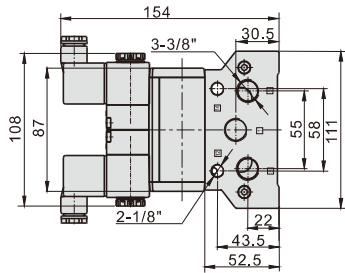

### ESV230+ESV202M+ESV203M

Note: "n" means the number of stations.  
The dimension of the grommet type (more than 3 stations), please refer to this drawing and the single grommet valve drawing.

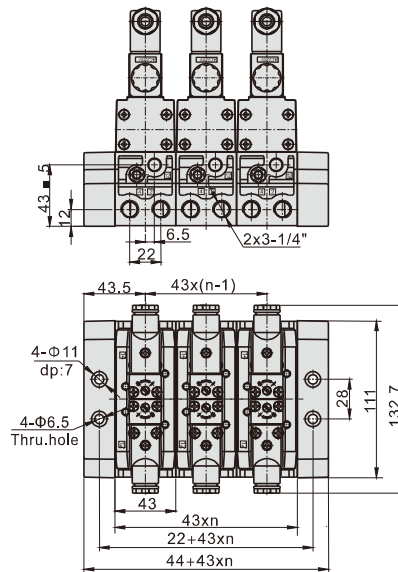
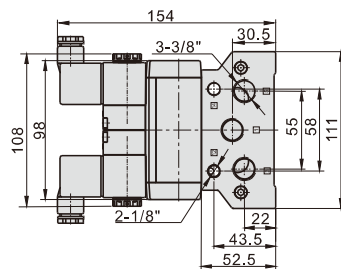

# ISO Standard solenoid valve(5/2 way, 5/3 way)

ESV200, 300, 400, 600 Series

## Dimensions(ESV300 Series)

ESV310(Terminal)

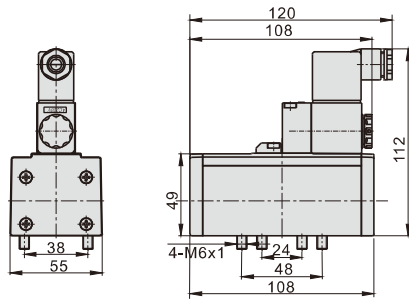

ESV310 (Grommet)

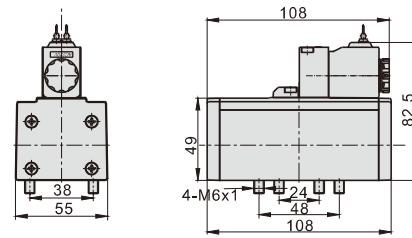

ESV320(Terminal)

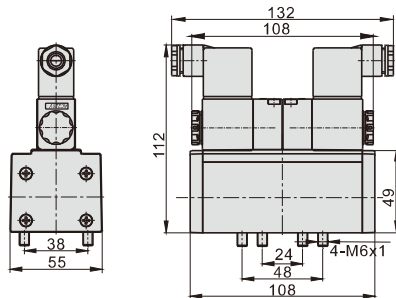

ESV320 (Grommet)

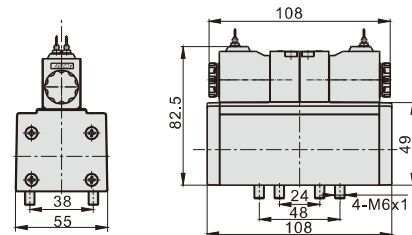

ESV330(Terminal)

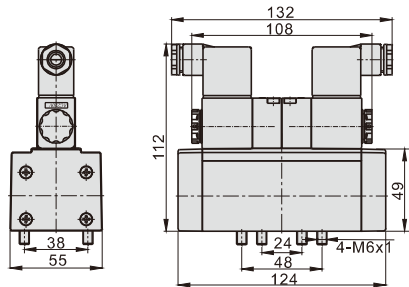

ESV330 (Grommet)

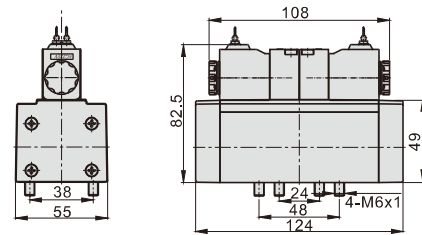

ESV301M

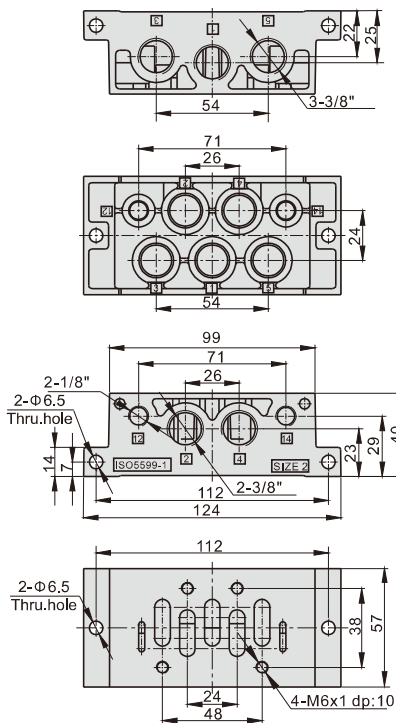

ESV302M

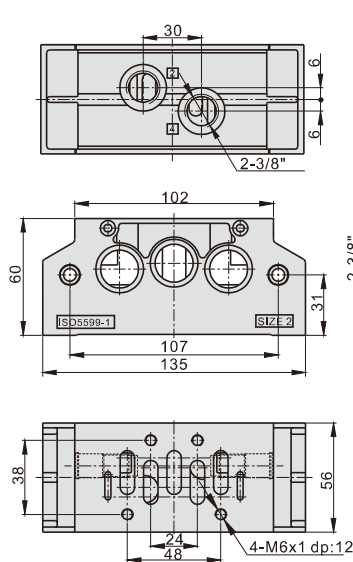

ESV303M

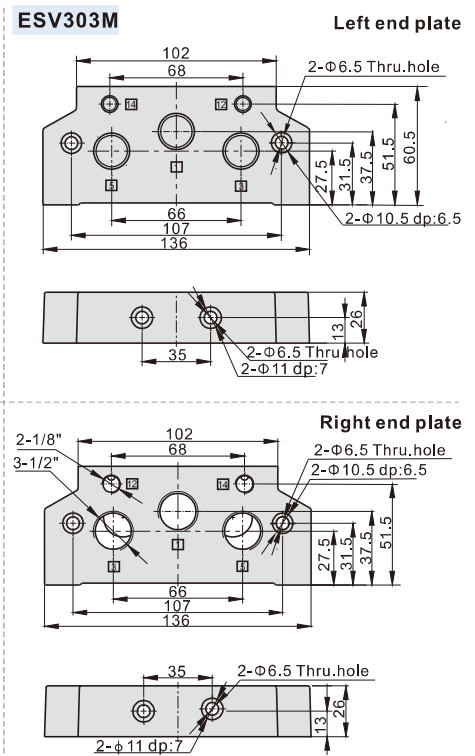

# ISO Standard solenoid valve(5/2 way, 5/3 way)

## ESV200, 300, 400, 600 Series

### ESV310+ESV301M

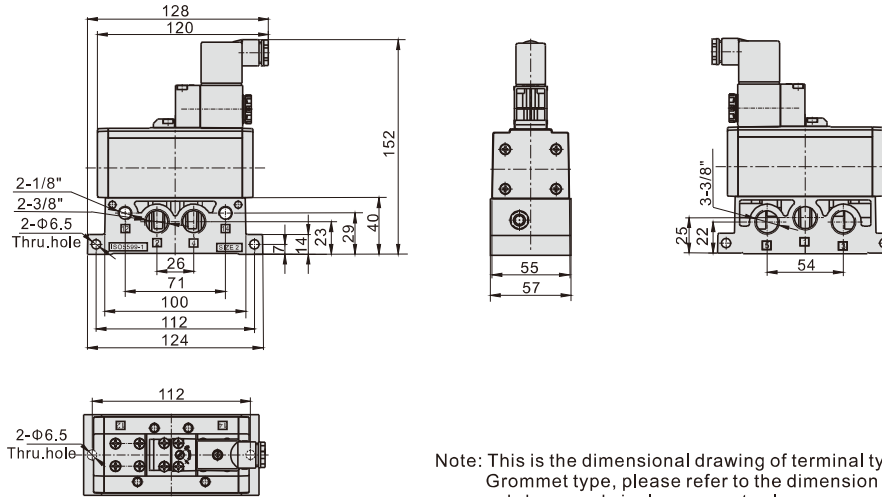

Note: This is the dimensional drawing of terminal type.  
Grommet type, please refer to the dimension of sub-base and single grommet valve.

### ESV320+ESV301M

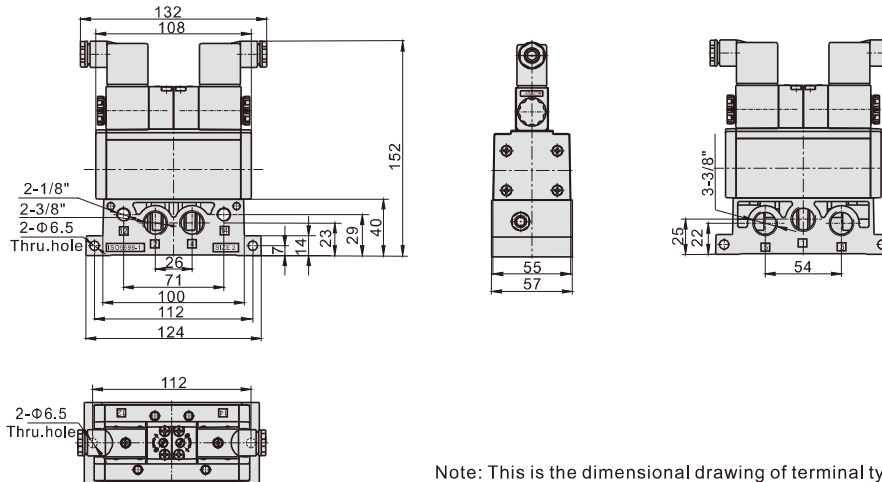

Note: This is the dimensional drawing of terminal type.  
Grommet type, please refer to the dimension of sub-base and single grommet valve.

### ESV330+ESV301M

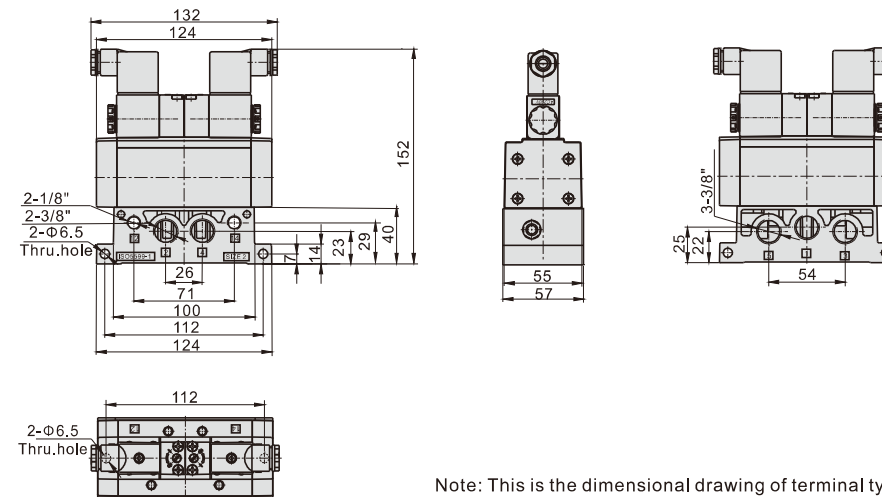

Note: This is the dimensional drawing of terminal type.  
Grommet type, please refer to the dimension of sub-base and single grommet valve.



# ISO Standard solenoid valve(5/2 way, 5/3 way)

## ESV200, 300, 400, 600 Series

### ESV310+ESV302M+ESV303M

Note: "n" means the number of stations.  
The dimension of the grommet type (more than 3 stations), please refer to this drawing and the single grommet valve drawing.

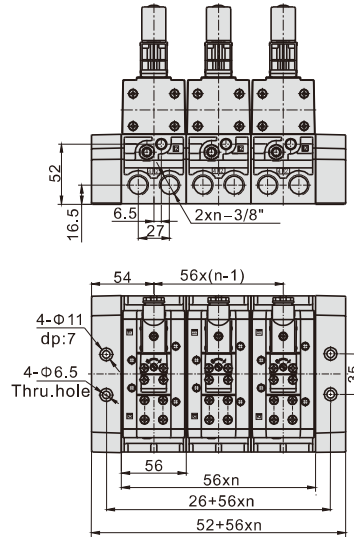
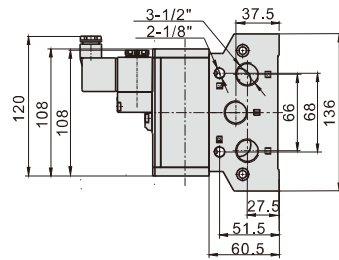

### ESV320+ESV302M+ESV303M

Note: "n" means the number of stations.  
The dimension of the grommet type (more than 3 stations), please refer to this drawing and the single grommet valve drawing.

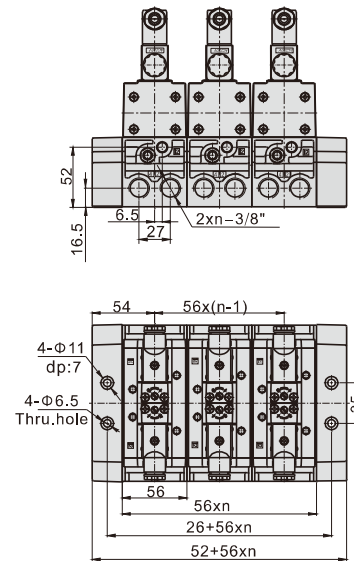
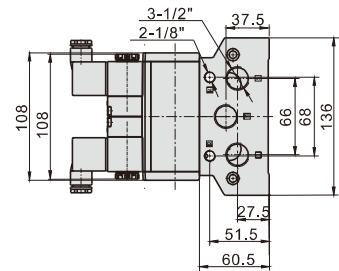

### ESV330+ESV302M+ESV303M

Note: "n" means the number of stations.  
The dimension of the grommet type (more than 3 stations), please refer to this drawing and the single grommet valve drawing.

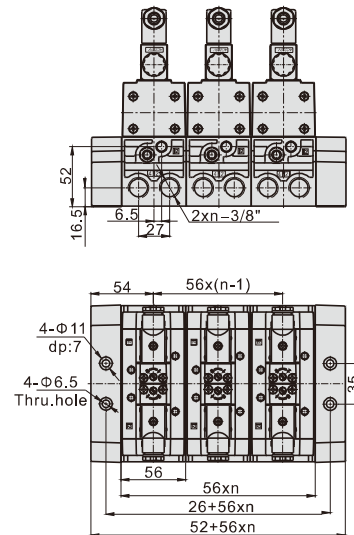
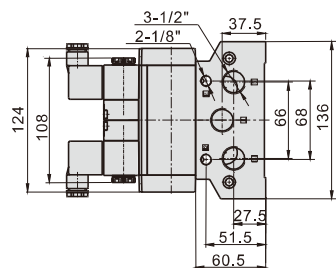

# ISO Standard solenoid valve(5/2 way, 5/3 way)

## ESV200, 300, 400, 600 Series

### Dimensions(ESV400 Series)

ESV410 (Terminal)

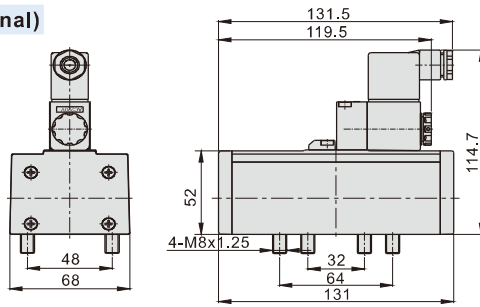

ESV410 (Grommet)

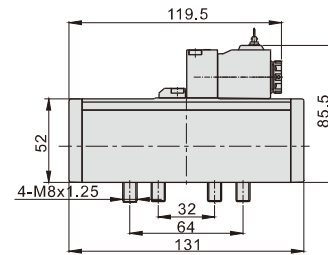

ESV420 (Terminal)

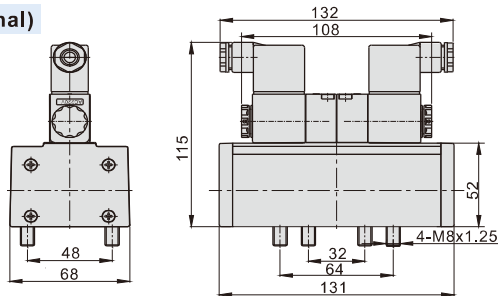

ESV420 (Grommet)

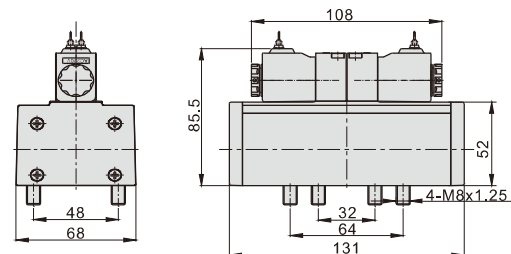

ESV430 (Terminal)

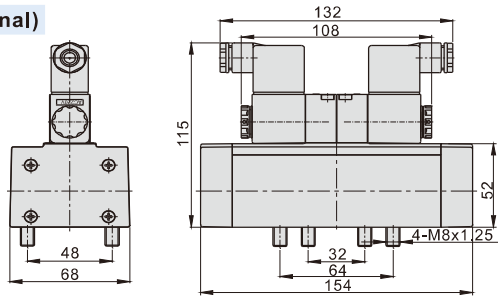

ESV430 (Grommet)

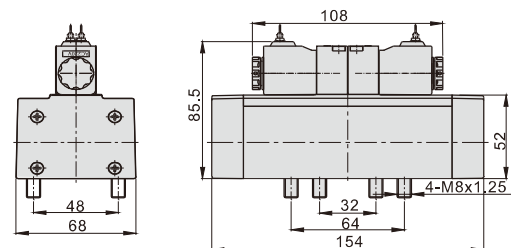

ESV401M

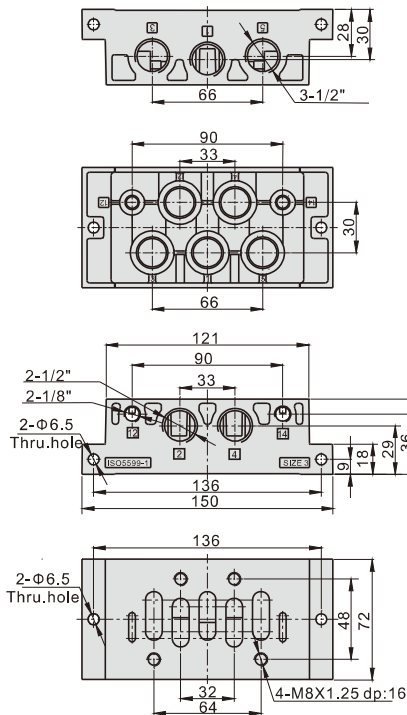

ESV402M

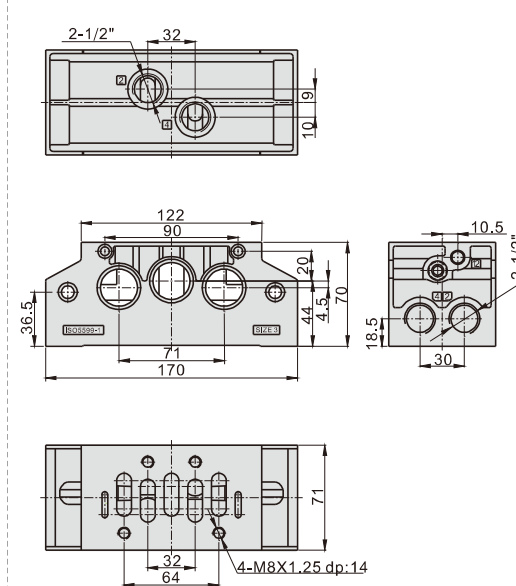

ESV403M

Left end plate

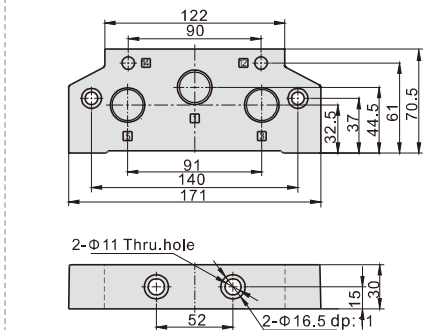

Right end plate

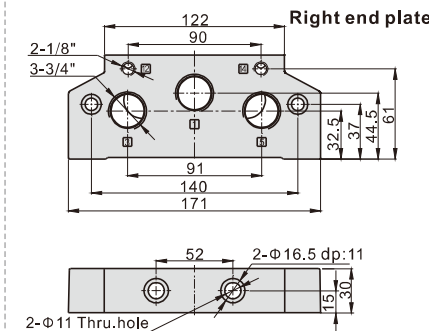

# ISO Standard solenoid valve(5/2 way, 5/3 way)

## ESV200, 300, 400, 600 Series

### ESV410+ESV401M

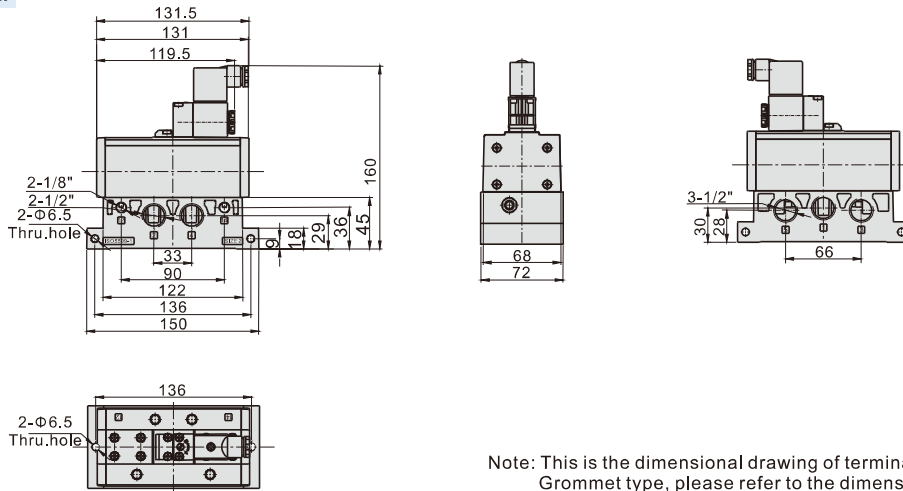

Note: This is the dimensional drawing of terminal type.  
Grommet type, please refer to the dimension of sub-base and single grommet valve.

### ESV420+ESV401M

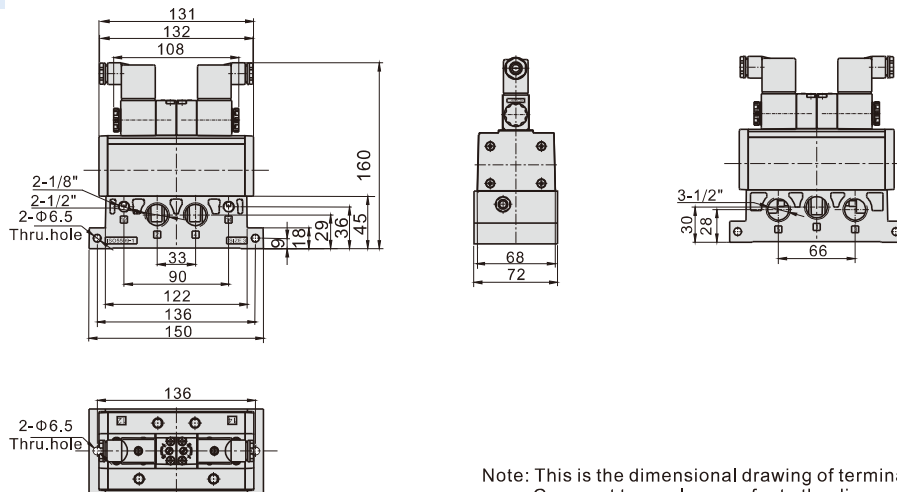

Note: This is the dimensional drawing of terminal type.  
Grommet type, please refer to the dimension of sub-base and single grommet valve.

### ESV430+ESV401M

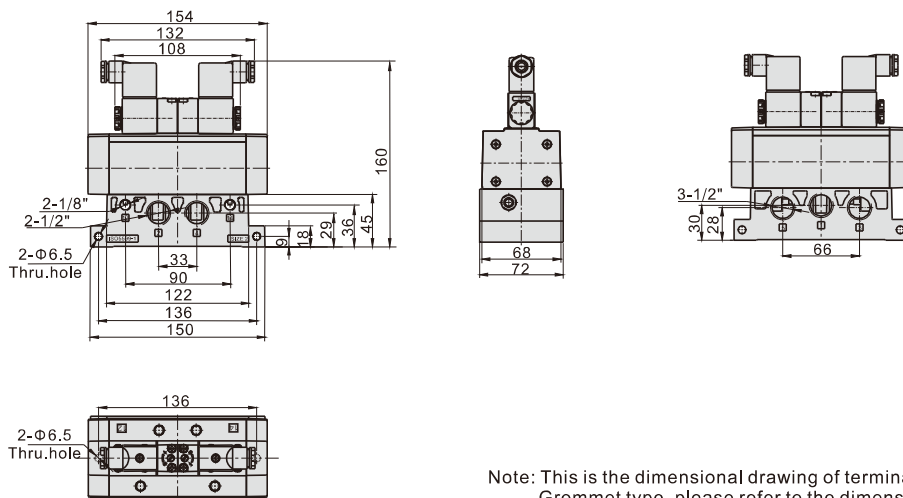

Note: This is the dimensional drawing of terminal type.  
Grommet type, please refer to the dimension of sub-base and single grommet valve.

# ISO Standard solenoid valve(5/2 way, 5/3 way)

## ESV200, 300, 400, 600 Series

### ESV410+ESV402M+ESV403M

Note: "n" means the number of stations.  
The dimension of the grommet type (more than 3 stations), please refer to this drawing and the single grommet valve drawing.

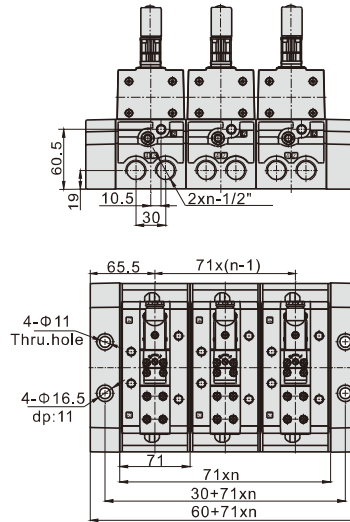
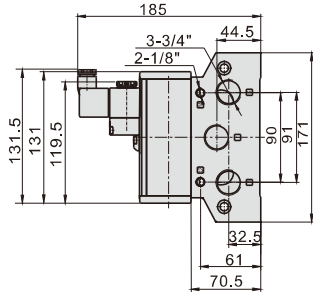

### ESV420+ESV402M+ESV403M

Note: "n" means the number of stations.  
The dimension of the grommet type (more than 3 stations), please refer to this drawing and the single grommet valve drawing.

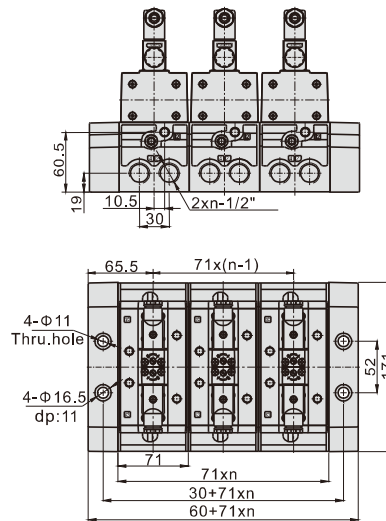
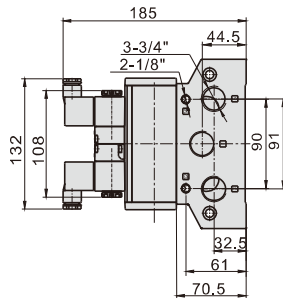

### ESV430+ESV402M+ESV403M

Note: "n" means the number of stations.  
The dimension of the grommet type (more than 3 stations), please refer to this drawing and the single grommet valve drawing.

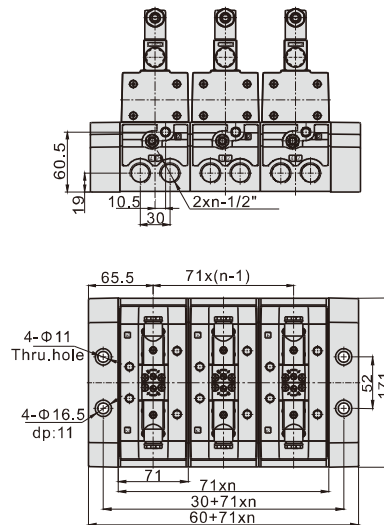
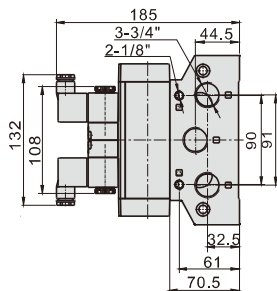

# ISO Standard solenoid valve(5/2 way, 5/3 way)

ESV200, 300, 400, 600 Series

## Dimensions(ESV600 Series)

### ESV610 (Terminal)

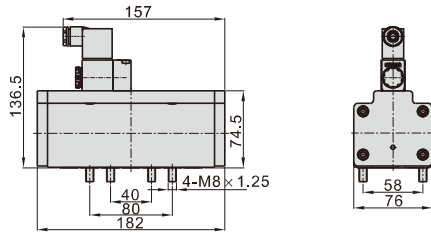

### ESV610 (Grommet)

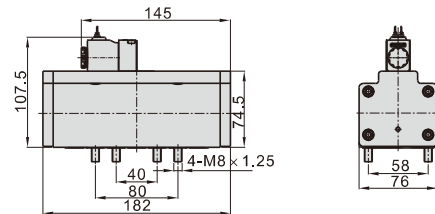

### ESV620 (Terminal)

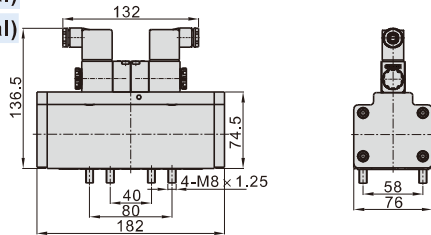

### ESV620(Grommet)

### ESV630(Grommet)

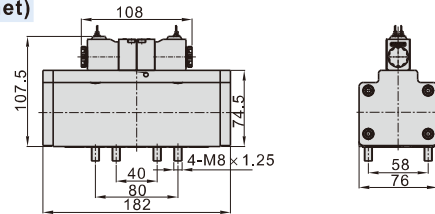

### ESV601M

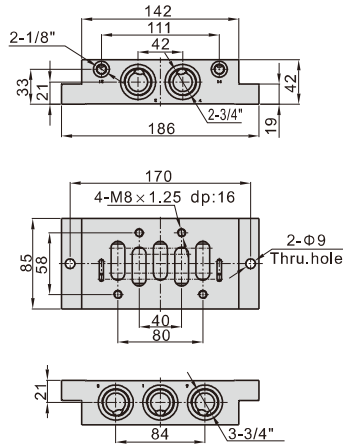

### ESV602M

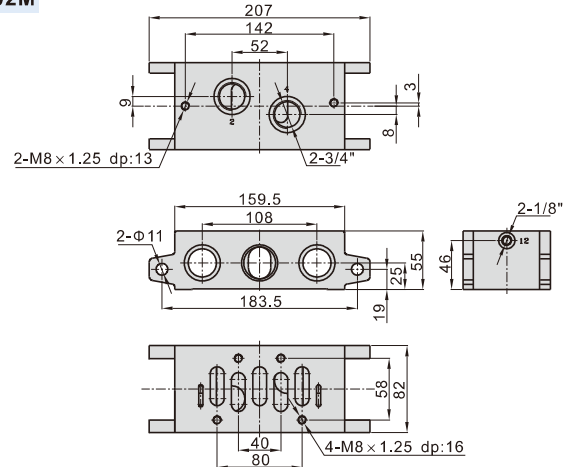

### ESV603M

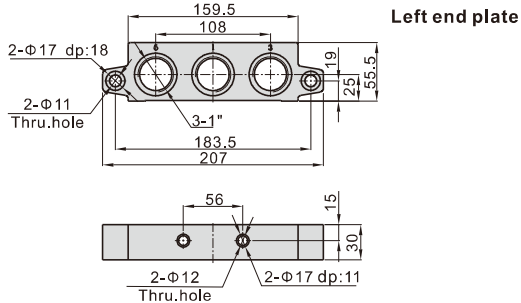

### ESV604M

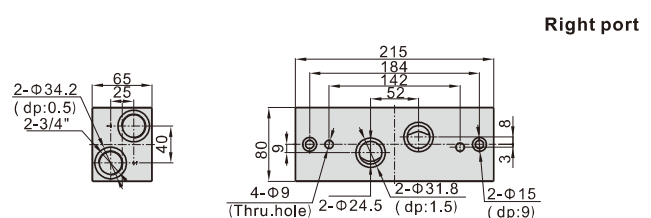
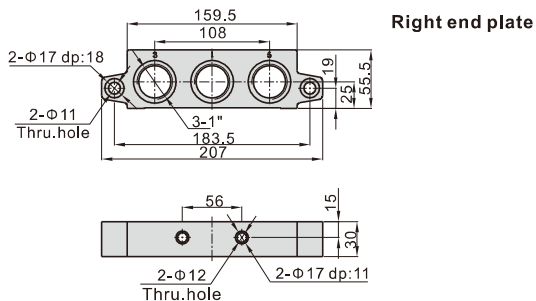
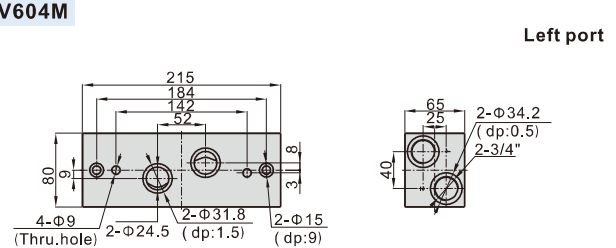

# ISO Standard solenoid valve(5/2 way, 5/3 way)

## ESV200, 300, 400, 600 Series

### ESV610+ESV601M

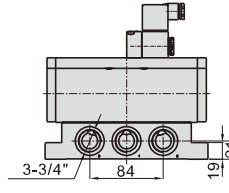
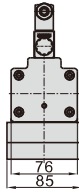
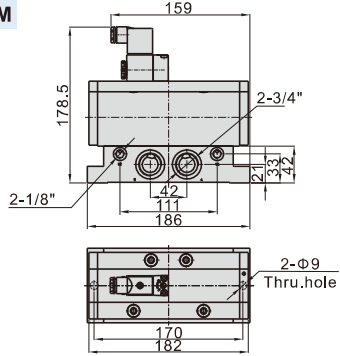

Note: This is the dimensional drawing of terminal type.  
Grommet type, please refer to the dimension of sub-base and single grommet valve.

### ESV620+ESV601M

### ESV630+ESV601M

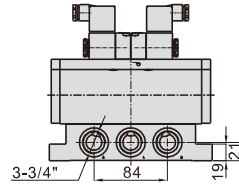
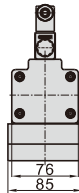
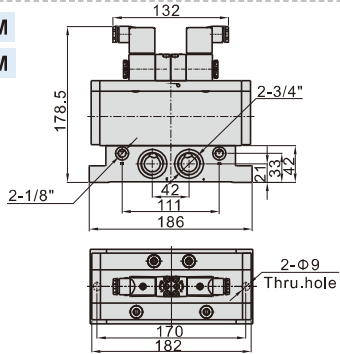

Note: This is the dimensional drawing of terminal type.  
Grommet type, please refer to the dimension of sub-base and single grommet valve.

### ESV610+ESV602M+ESV603M+ESV604M

Note: "n" means the number of stations.  
The dimension of the grommet type (more than 3 stations), please refer to this drawing and the single grommet valve drawing.

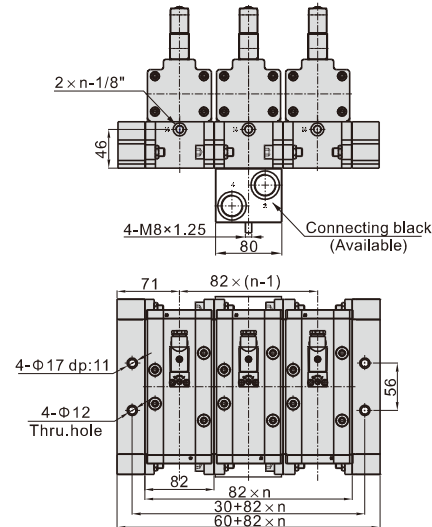
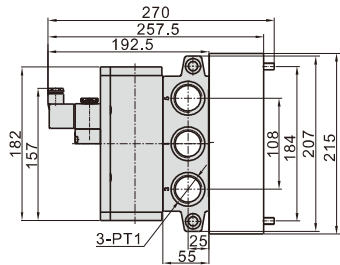

### ESV620+ESV602M+ESV603M+ESV604M

### ESV630+ESV602M+ESV603M+ESV604M

Note: "n" means the number of stations.  
The dimension of the grommet type (more than 3 stations), please refer to this drawing and the single grommet valve drawing.

